

AR

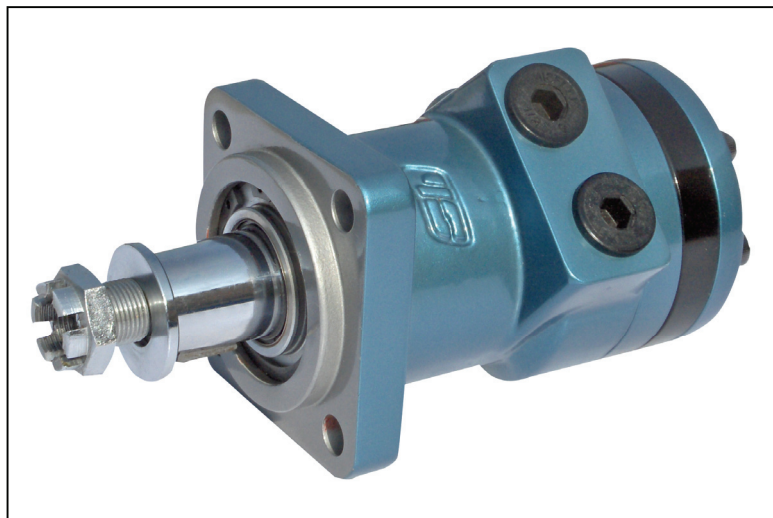

MOTORI ORBITALI

ORBITAL MOTORS

CARATTERISTICHE DEL MOTORE MOTOR FEATURES

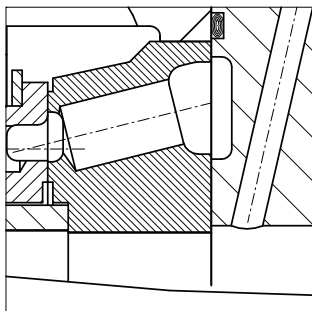

Distribuzione frontale compensata che garantisce minime perdite per trafilamento e recupero dei giochi di usura.

Pressure compensated valve plate maintains minimal leakage and provides compensated wear.

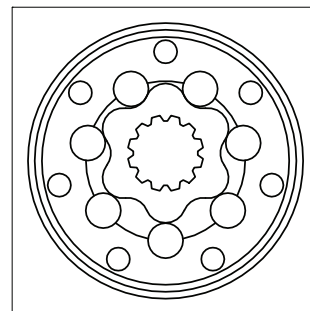
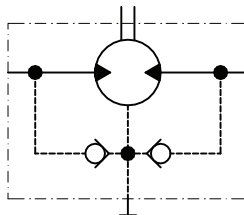

Organo motore roller a 7 camere. 7 sockets - 6 teeth roller set.

Valvole interne di drenaggio per l'utilizzo con pressioni di scarico elevate senza linea di drenaggio collegata.

Built-in check valves to relieve case pressure to the low pressure side of the motor and adequate for application without the need to connect the drain.

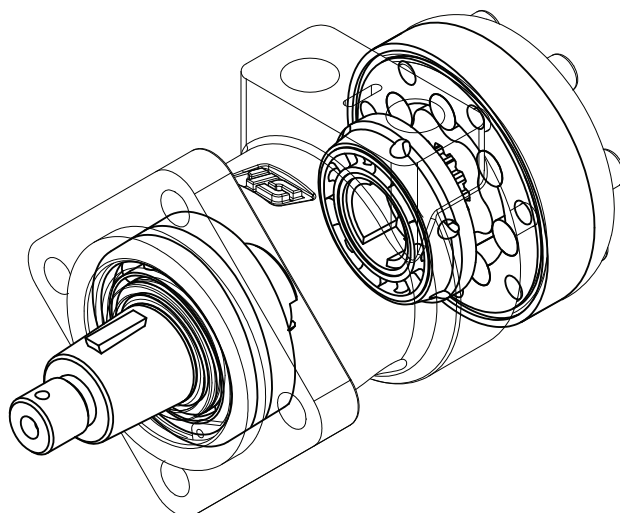

Due opzioni supporto con elevate capacità di carico radiali e assiali.

Two option of bearing for heavy shaft loads.

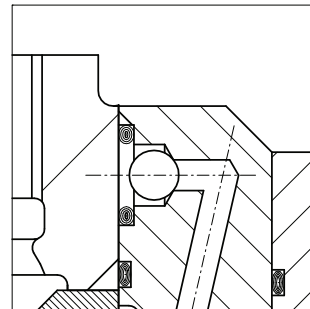
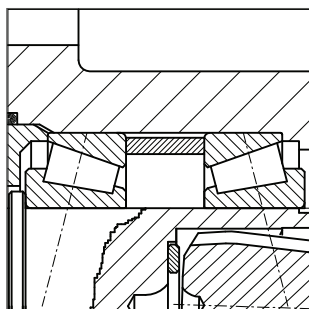

CODICE DI ORDINAZIONE ORDERING CODE

Serie Series		Cilindrata Displacement		Flangia Mounting		Alberi Shafts		Opzioni Options	
ARS		130		D		C25			
CODICE CODE	Serie Series	CODICE CODE	Cilindrata Displacement	CODICE CODE	Flangia Mounting	CODICE CODE	Alberi Shafts	CODICE CODE	Opzioni Options
ARS	Motore (*) Motor (*)	50	51.6 cm ³ /giro [3.14 in ³ /rev]	N	2 Fori ⁽⁴⁾ 2 Bolts ⁽⁴⁾	C25	Cilindrico Ø25 mm Parallel keyed 0.984 in		Nessuna opzione Without options
ARSW	Motore (*) Motor (*)	80	80.4 cm ³ /giro [4.9 in ³ /rev]	D	4 Fori ⁽¹⁾ 4 Bolts ⁽¹⁾	C32	Cilindrico Ø32 mm ⁽¹⁾ Parallel keyed 1.259 in ⁽¹⁾	HPS	Guarnizione alta pressione ⁽⁵⁾ High Pressure Seal ⁽⁵⁾
ARF	Motore (*) Motor (*)	100	100 cm ³ /giro [6.1 in ³ /rev]	DR	2 Fori ⁽³⁾ 2 Bolts ⁽³⁾	S32	Scanalato Z14 12/24 DP ⁽¹⁾ 14T 12/24 DP Spline ⁽¹⁾	FP	Freno posteriore ⁽¹⁾ Brake motor ⁽¹⁾
		130	125.7 cm ³ /giro [7.66 in ³ /rev]	DS1	2 Fori ⁽³⁾ 2 Bolts ⁽³⁾	SD25	Scanalato 1"6B ⁽¹⁾ 1"6B Tooth Spline ⁽¹⁾	TAC	Attacco contagiri ⁽²⁾ Rev-counter connection ⁽²⁾
		160	160 cm ³ /giro [9.76 in ³ /rev]	DS2	2 Fori ⁽³⁾ 2 Bolts ⁽³⁾	CN32	Conico ⁽¹⁾ Tapered ⁽¹⁾	TAC-E	Contagiri elettronico ⁽²⁾ Electronic tachometer ⁽²⁾
		200	200 cm ³ /giro [12.2 in ³ /rev]					BFL	Base attacco speciale ⁽³⁾ Special connection base ⁽³⁾
		250	250 cm ³ /giro [15.2 in ³ /rev]						
		315	314.5 cm ³ /giro [19.1 in ³ /rev]						
		400	393 cm ³ /giro [23.9 in ³ /rev]						

(1) Disponibile con serie ARS e ARSW
Available with ARS and ARSW series

(2) Non disponibile con serie ARSW
Not available with ARSW series

(3) Disponibile con serie ARS (Speciale a richiesta)
Available with ARS series (Special on request)

(4) Disponibile con serie ARF
Available with ARF series

(5) Disponibile con serie ARS
Available with ARS series

In caso di caratteristiche non elencate, contattare Uff. Tecnico.
Please contact technical department for not listed features.

(*) Il motore è disponibile solo con attacchi BSPP
The motor is available only with BSPP ports

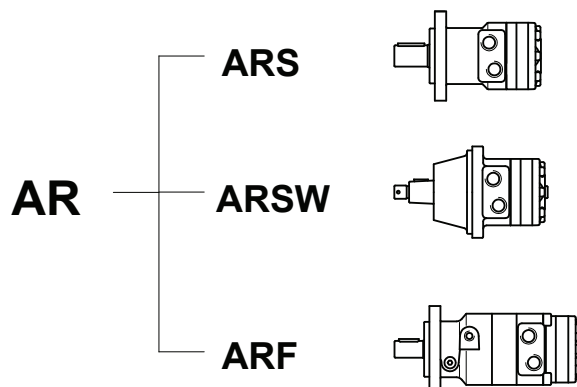

**VERSIONI
VERSIONS**

DISPONIBILE SU MOTORI
AVAILABLE WITH MOTORS

HPS

Guarnizione alta pressione
High Pressure Seal

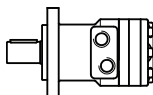

ARS

FP

Freno posteriore
Brake-motor

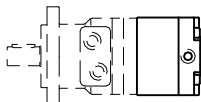

ARS - ARSW

TAC

Attacco contagiri
Rev-counter connection

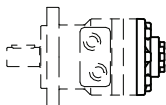

ARS - ARF

TAC-E

Contagiri elettronico
Electronic tachometer

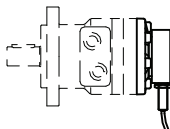

ARS - ARF

BFL

Base attacco speciale
Special connection base

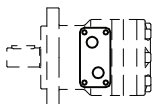

ARS

Speciale a richiesta
Special on request

CARATTERISTICHE TECNICHE TECHNICAL SPECIFICATIONS

Motore Motor	Cilindrata Displacement	Pressione max ingr. Max. input pressure		Pressione diff. max. Max. differential pressure		Coppia max. Max. torque		Portata max. Max. flow		Velocità max. Max. speed		Potenza max. Max. power	
	cm ³ /rev [in ³ /rev]	bar [psi]		bar [psi]		Nm [lbf-ft]		l/min [U.S. gpm]		giri/min [rpm]		kW [hp]	
AR 50	51.6 [3.14]	Cont	175 [2538]	Cont	160 [2320]	Cont	118 [86.9]	Cont	40 [11]	Cont	775	Cont	8.5 [11.3]
		Int*	190 [2755]	Int*	190 [2755]	Int*	136 [100.2]	Int*	50 [13]	Int*	970	Int*	10.2 [13.6]
		Peak**	250 [3625]	Peak**	250 [3625]								
AR 80	80.4 [4.9]	Cont	175 [2538]	Cont	160 [2320]	Cont	184 [135.6]	Cont	60 [16]	Cont	746	Cont	12.6 [16.8]
		Int*	190 [2755]	Int*	190 [2755]	Int*	210 [154.7]	Int*	75 [20]	Int*	933	Int*	15.2 [20.3]
		Peak**	250 [3625]	Peak**	250 [3625]								
AR 100	100 [6.1]	Cont	175 [2538]	Cont	160 [2320]	Cont	230 [169.5]	Cont	60 [16]	Cont	600	Cont	13 [17.4]
		Int*	190 [2755]	Int*	190 [2755]	Int*	260 [191.6]	Int*	75 [20]	Int*	750	Int*	15.5 [20.7]
		Peak**	250 [3625]	Peak**	250 [3625]								
AR 130	125.7 [7.66]	Cont	175 [2538]	Cont	150 [2175]	Cont	270 [198.9]	Cont	60 [16]	Cont	477	Cont	12 [16]
		Int*	190 [2755]	Int*	190 [2755]	Int*	330 [243.2]	Int*	75 [20]	Int*	597	Int*	14.2 [19]
		Peak**	250 [3625]	Peak**	250 [3625]								
AR 160	160 [9.76]	Cont	175 [2538]	Cont	150 [2175]	Cont	340 [250.5]	Cont	60 [16]	Cont	375	Cont	12.4 [16.6]
		Int*	190 [2755]	Int*	190 [2755]	Int*	420 [309.5]	Int*	75 [20]	Int*	470	Int*	15.7 [21]
		Peak**	250 [3625]	Peak**	250 [3625]								
AR 200	200 [12.2]	Cont	175 [2538]	Cont	125 [1813]	Cont	350 [257.9]	Cont	65 [17]	Cont	325	Cont	10.8 [14.4]
		Int*	190 [2755]	Int*	175 [2538]	Int*	480 [353.7]	Int*	75 [20]	Int*	375	Int*	15.5 [20.7]
		Peak**	250 [3625]	Peak**	230 [3335]								
AR 250	250 [15.2]	Cont	175 [2538]	Cont	110 [1595]	Cont	380 [280]	Cont	65 [17]	Cont	260	Cont	9.8 [13.1]
		Int*	190 [2755]	Int*	155 [2248]	Int*	520 [383.2]	Int*	80 [21]	Int*	320	Int*	13.4 [17.9]
		Peak**	250 [3625]	Peak**	200 [2900]								
AR 315	314.5 [19.1]	Cont	175 [2538]	Cont	80 [1160]	Cont	340 [250.5]	Cont	65 [17]	Cont	207	Cont	6.1 [8.1]
		Int*	190 [2755]	Int*	120 [1740]	Int*	510 [375.8]	Int*	80 [21]	Int*	254	Int*	8.5 [11.3]
		Peak**	250 [3625]	Peak**	150 [2175]								
AR 400	393 [23.9]	Cont	175 [2538]	Cont	65 [943]	Cont	358 [263.8]	Cont	65 [17]	Cont	165	Cont	4.7 [6.2]
		Int*	190 [2755]	Int*	100 [1450]	Int*	510 [375.8]	Int*	80 [21]	Int*	203	Int*	6 [8]
		Peak**	250 [3625]	Peak**	120 [1740]								

Prove eseguite con olio 37 cSt a 45°C. / Test conditions: 37 cSt oil at 45°C.

Motore Motor	Cilindrata - Displacement																														
	50		80		100		130		160		200		250		315		400														
Velocità Speed (rpm)	0	100	>	0	100	>	0	100	>	0	100	>	0	100	>	0	100	>	0	100	>	0	100	>	0	100	>	0	100	>	
Press.max scarico cont senza drenaggio (bar) Max cont. Return pressure without drain line (bar)	ARS	75	50	25	75	50	25	75	50	25	75	50	25	75	50	25	75	50	25	75	50	-	75	50	-	75	50	-	75	50	-
Conversioni Conversions:	.. /FP****	-	-	-	-	-	-	-	-	-	-	-	-	-	-	-	-	-	-	-	-	-	-	-	-	-	-	-	-	-	
Press.max scarico con drenaggio bar[psi] Max return pressure with drain line bar [psi]	TAC	20			20			20			20			20			20			20			20			20			20		
Coppia min di spunto a press diff. max Min starting torque N [lbf]	Cont.	62 [46]			120 [88]			150 [111]			187 [138]			242 [178]			282 [208]			310 [228]			269 [198]			286 [211]					
	Int.*	70 [51.6]			139 [102]			172 [127]			230 [170]			294 [217]			390 [287]			415 [306]			397 [293]			413 [304]					

* Le condizioni intermittenti non devono durare più del 10% di ogni minuto. / Intermittent duty must not exceed 10% each minute.

** Le condizioni di picco non devono durare più dell'1% di ogni minuto. / Peak duty must not exceed 1% each minute.

*** Le condizioni di contropressione devono essere le più basse fra il motore e la versione. / The back up pressure must be lower between the motor and the motor version considered.

**** È indispensabile l'utilizzo del drenaggio per lo smaltimento del calore. / In order to eliminate overheating it is necessary to use the drain port.

MASSIMA PRESSIONE AMMESSA SULLA GUARNIZIONE ALBERO MAX PERMISSIBLE SHAFT SEAL PRESSURE

I motori ARS sono forniti nella versione con guarnizioni standard (diagramma Standard) o nella versione con guarnizioni ad alta pressione (diagramma HPS). Per condizioni di pressione e velocità non contemplate dal presente grafico si consiglia di contattare la S.A.M. Hydraulik.

N.B.: Sulle versioni con Tachimetro e Freno non è possibile installare guarnizioni HPS.

ARS Motor are supplied in standard seal version (Standard chart) or in HPS seal version (HPS chart). For pressure and speeds not showed in the curve below, please contact S.A.M. Hydraulik.

N.B.: Tachometer and Brake versions is not available with HPS seals.

STANDARD

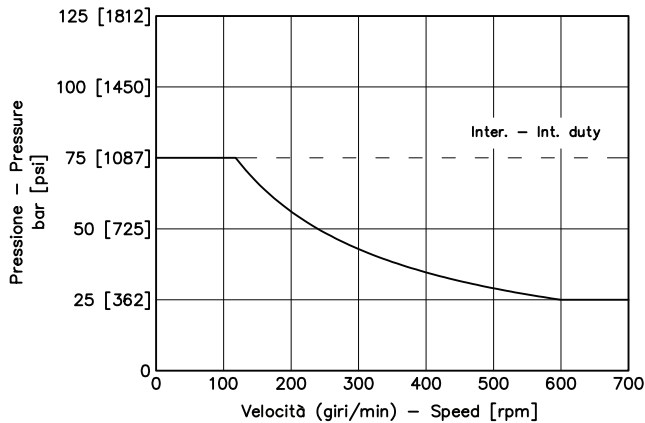

HPS

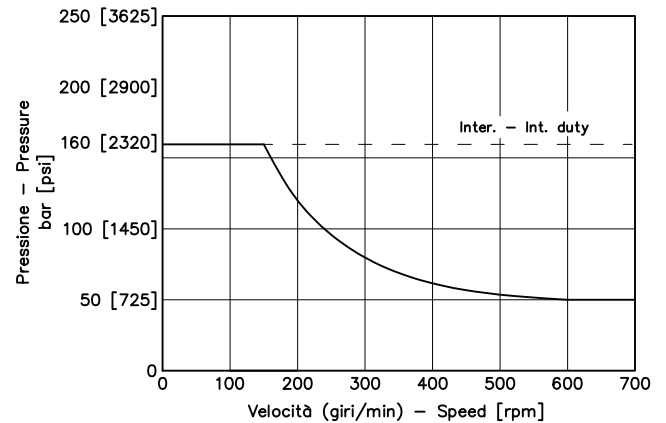

PERDITE DI CARICO PER ATTRAVERSAMENTO PRESSURE LOSS

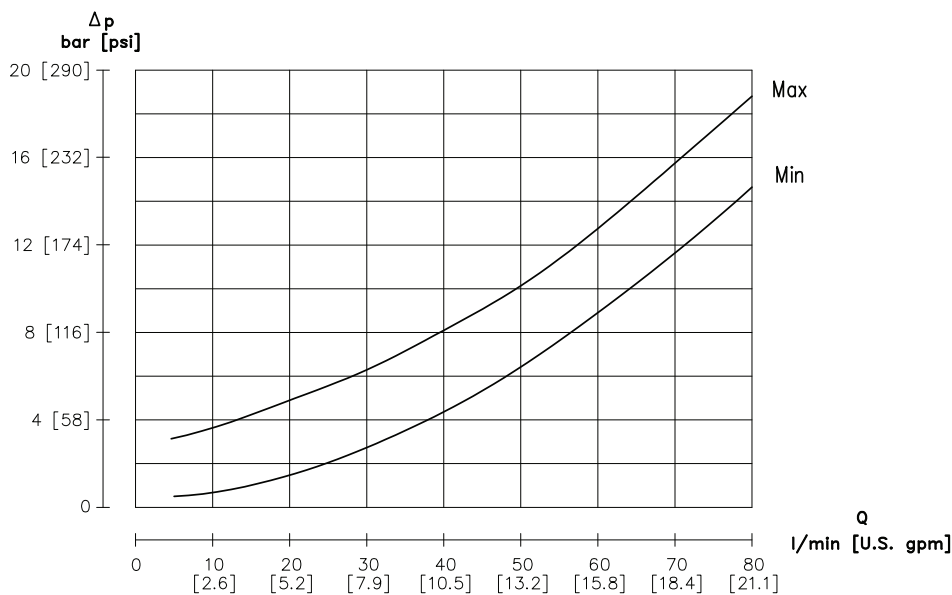

Tendenzialmente i motori con bassa cilindrata si posizionano verso la curva MAX, viceversa i motori con alta cilindrata si posizionano verso la curva MIN.

Low displacement motors have the tendency to operate near the "Max" curve, while high displacement ones have the opposite tendency.

Linguetta A 10x8x40 DIN 6885

A 10x8x40 DIN 6885 key

ALBERO
SHAFT C32

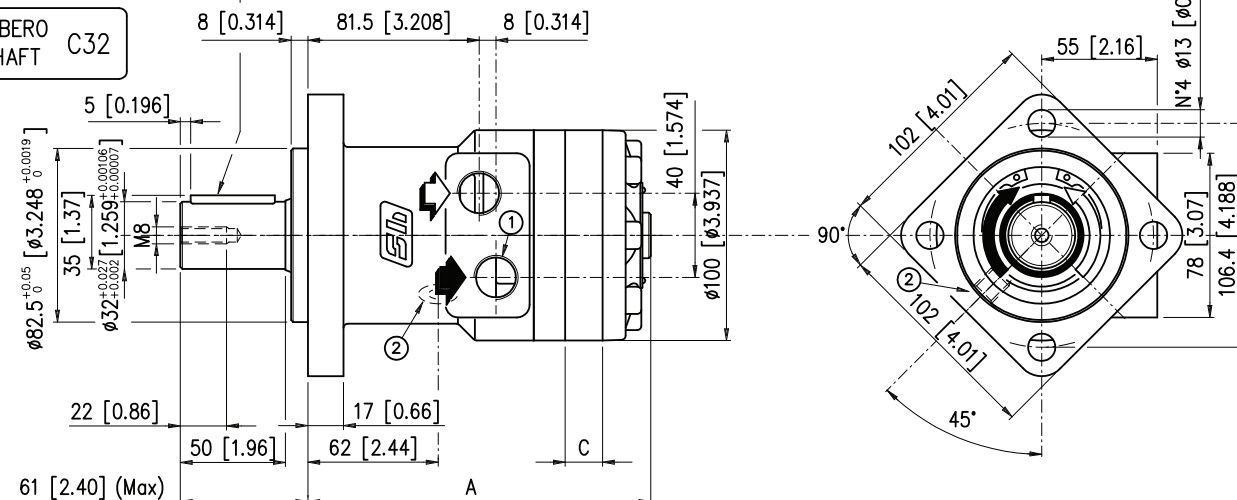

ANS B92.1 1970 Flat root side fit D.P. Z14 12/24

Angolo di pressione - Pressure angle 30°

- 1) N° 2 fori di alimentazione 1/2 G (BSPP) profondità filetto 18mm
No. 2 1/2 G (BSPP) main ports thread depth 0.70 in
- 2) Drenaggio motore 1/4 G (BSPP) profondità filetto 12mm
1/4 G (BSPP) drain motor thread depth 0.472 in

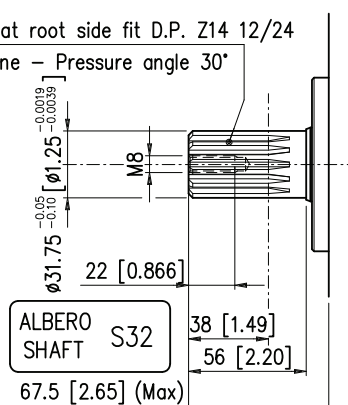

ALBERO
SHAFT S32

Linguetta A 8x7x30 DIN 6885

A 8x7x30 DIN 6885 key

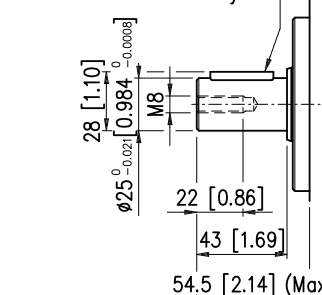

ALBERO
SHAFT C25

Linguetta 6x9 UNI 6606-69

6x9 UNI 6606-69 key

Conicità 1:10

1:10 taper

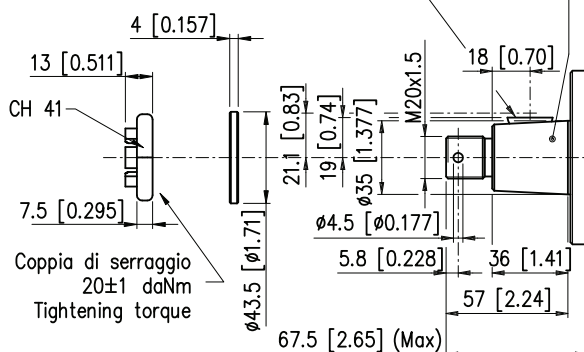

ALBERO
SHAFT CN32

Profilo SAE 1"6B

SAE 1"6B Profile

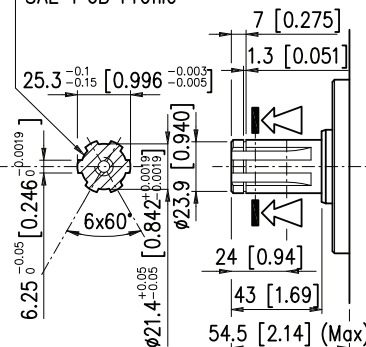

ALBERO
SHAFT SD25

		ARS 50	ARS 80	ARS 100	ARS 130	ARS 160	ARS 200	ARS 250	ARS 315	ARS 400
A	mm [in]	152.5 [6.00]	157.5 [6.20]	160.9 [6.33]	165.3 [6.50]	171.3 [6.74]	178.3 [7.01]	187 [7.36]	198.3 [7.80]	211.8 [8.33]
C	mm [in]	9 [0.354]	14 [0.551]	17.4 [0.68]	21.8 [0.85]	27.8 [1.09]	34.8 [1.37]	43.5 [1.71]	54.8 [2.15]	68.38 [2.69]
Pesi - Weight	kg [lb]	7.5 [16.5]	7.7 [16.9]	7.9 [17.4]	8.2 [18]	8.4 [18.5]	8.8 [19.3]	9.2 [20.2]	9.7 [21.3]	10.4 [22.9]

Linguetta A 10x8x40 DIN 6885

A 10x8x40 DIN 6885 key

ALBERO SHAFT C32

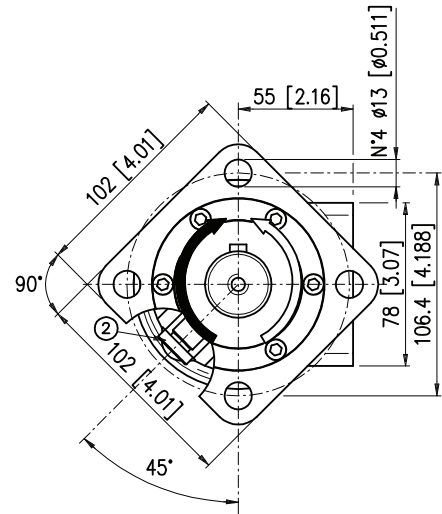
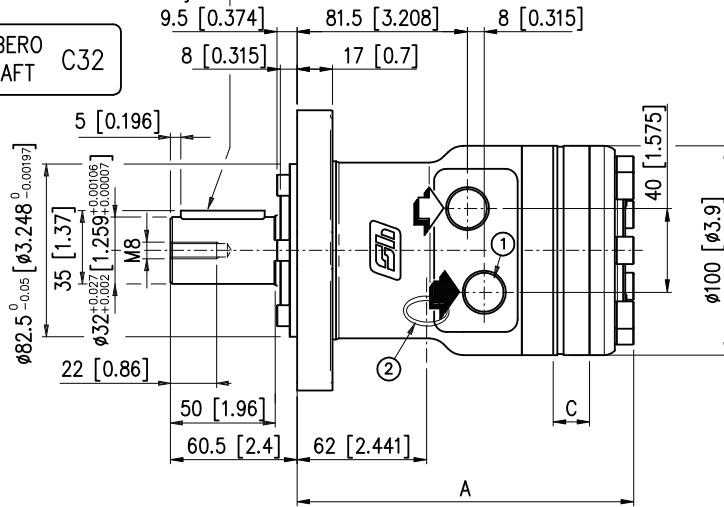

Linguetta A 8x7x30 DIN 6885

A 8x7x30 DIN 6885 key

ALBERO SHAFT C25

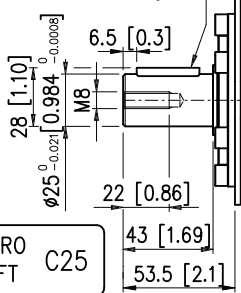

ANS B92.1 1970 Flat root side fit D.P. Z14 12/24

Angolo di pressione - Pressure angle 30°

ALBERO SHAFT S32

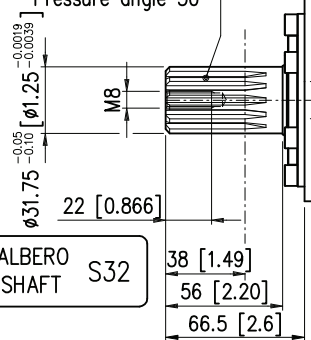

Profilo SAE 1"6B

SAE 1"6B Profile

ALBERO SHAFT SD25

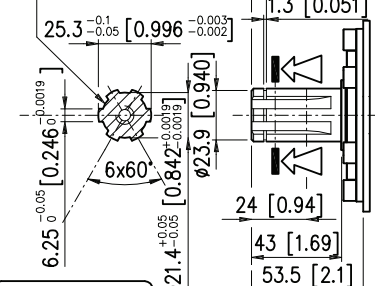

Linguetta 6x9 UNI 6606-69

6x9 UNI 6606-69 key

Conicità' 1:10

1:10 taper

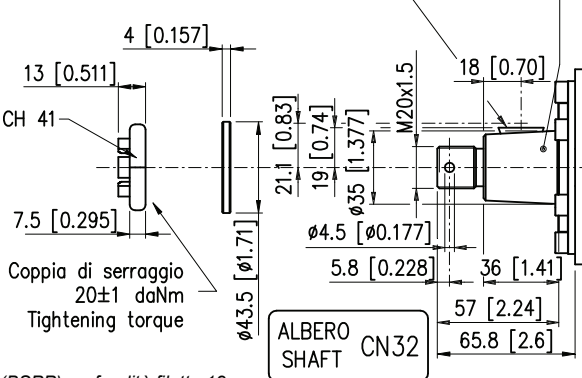

Linguetta 5/16"x5/16"x1"1/4 UNI 6604

5/16"x5/16"x1"1/4 UNI 6604 key

ALBERO SHAFT C31.75

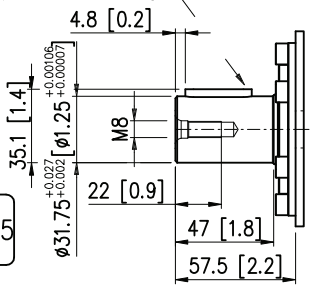

- 1) N° 2 fori di alimentazione 1/2 G (BSPP) profondità filetto 18mm
No. 2 1/2 G (BSPP) main ports thread depth 0.70 in
- 2) Drenaggio motore 1/4 G (BSPP) profondità filetto 12mm
1/4 G (BSPP) drain motor thread depth 0.472 in

		ARS 50	ARS 80	ARS 100	ARS 130	ARS 160	ARS 200	ARS 250	ARS 315	ARS 400
A	mm [in]	152 [5.98]	157 [6.18]	161 [6.34]	165 [6.50]	171 [6.73]	178 [7.01]	187 [7.36]	198 [7.79]	212 [8.35]
C	mm [in]	9 [0.354]	14 [0.551]	17.4 [0.68]	21.8 [0.85]	27.8 [1.09]	34.8 [1.37]	43.5 [1.71]	54.8 [2.15]	68.38 [2.69]
Pesi - Weight	kg [lb]	7.5 [16.5]	7.7 [16.9]	7.9 [17.4]	8.2 [18]	8.4 [18.5]	8.8 [19.3]	9.2 [20.2]	9.7 [21.3]	10.4 [22.9]

FLANGIA TIPO "DR" (QUADRATA, 4 FORI FILETTATI)
"DR" TYPE FLANGE (SQUARE, 4 THREADED BOLTS)

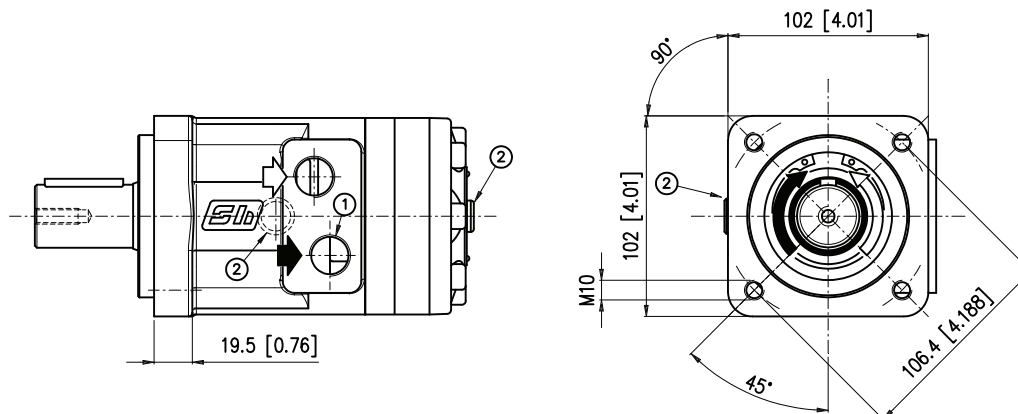

Per le dimensioni non indicate fare riferimento al disegno del motore ARS flangia "D". Non disponibile in versione HPS
Refer to ARS "D" flange drawing for any dimension here not indicated. Not available in HPS version

FLANGIA TIPO "DS1" (2 FORI)
"DS1" TYPE FLANGE (2 BOLTS)

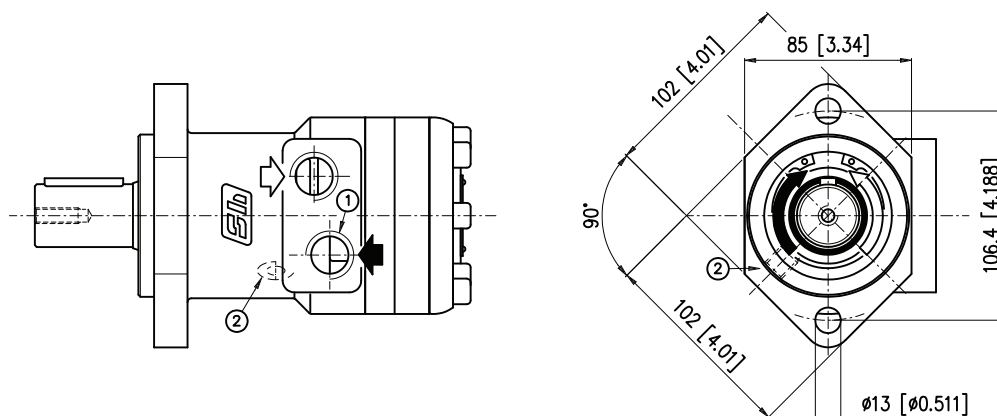

Per le dimensioni non indicate fare riferimento al disegno del motore ARS flangia "D". Non disponibile in versione HPS
Refer to ARS "D" flange drawing for any dimension here not indicated. Not available in HPS version

FLANGIA TIPO "DS2" (2 FORI)
"DS2" TYPE FLANGE (2 BOLTS)

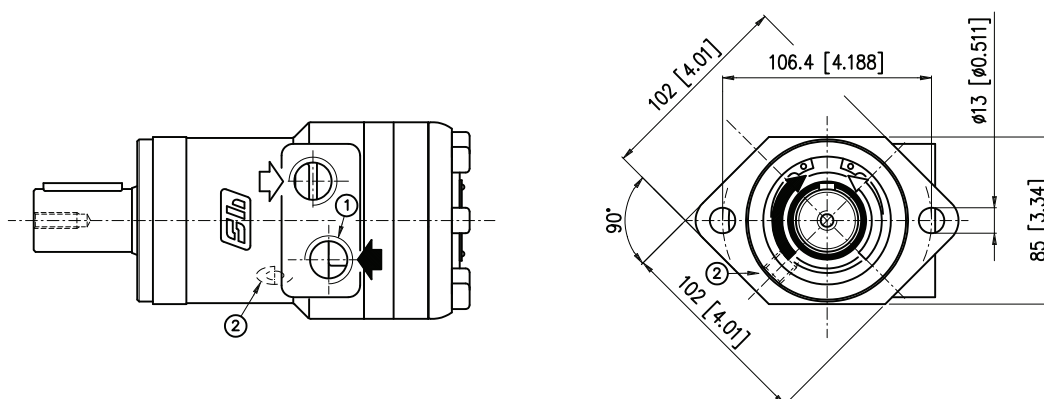

Per le dimensioni non indicate fare riferimento al disegno del motore ARS flangia "D". Non disponibile in versione HPS
Refer to ARS "D" flange drawing for any dimension here not indicated. Not available in HPS version

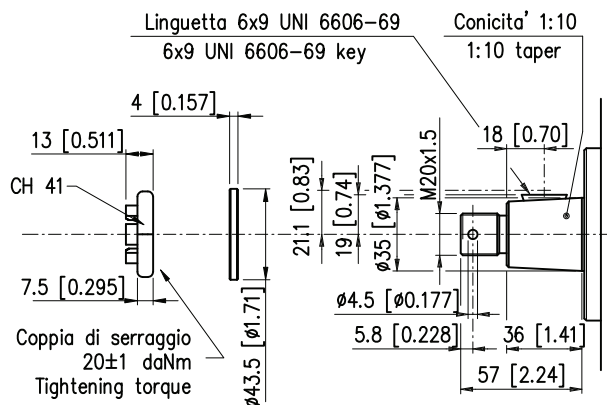
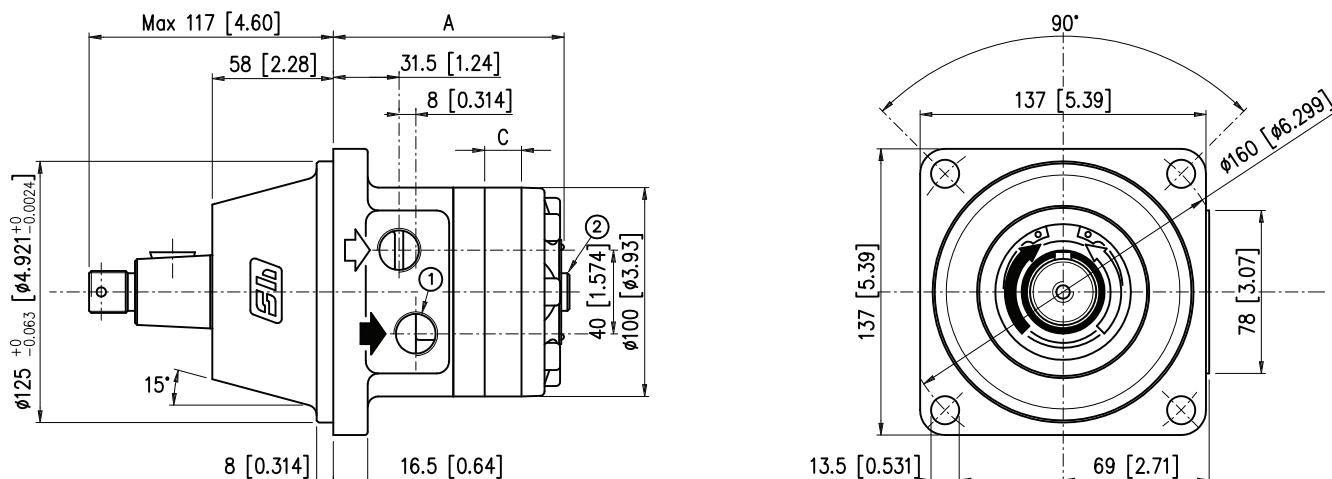

- 1) N° 2 fori di alimentazione 1/2 G (BSPP) profondità filetto 18mm
No. 2 1/2 G (BSPP) main ports thread depth 0.70 in
- 2) Drenaggio motore 1/4 G (BSPP) profondità filetto 12mm
1/4 G (BSPP) drain motor thread depth 0.472 in

Sono disponibili a richiesta anche i seguenti alberi: C32 - C25 - SD25 - S32
The following shafts are available upon request : C32 - C25 - SD25 - S32

		ARSW 50	ARSW 80	ARSW 100	ARSW 130	ARSW 160	ARSW 200	ARSW 250	ARSW 315	ARSW 400
A	mm [in]	102.5 [4.03]	107.5 [4.23]	110.9 [4.36]	115.3 [4.53]	121.3 [4.77]	128.3 [5.05]	137 [5.39]	148.3 [5.83]	161.8 [6.37]
C	mm [in]	9 [0.354]	14 [0.551]	17.4 [0.68]	21.8 [0.85]	27.8 [1.09]	34.8 [1.37]	43.5 [1.71]	54.8 [2.15]	68.38 [2.69]
Pesi - Weight	kg [lb]	9.8 [21.5]	10.1 [22.2]	10.3 [22.7]	10.5 [23.1]	10.8 [23.8]	11.2 [24.6]	16.1 [35.4]	12.1 [26.6]	12.8 [28.2]

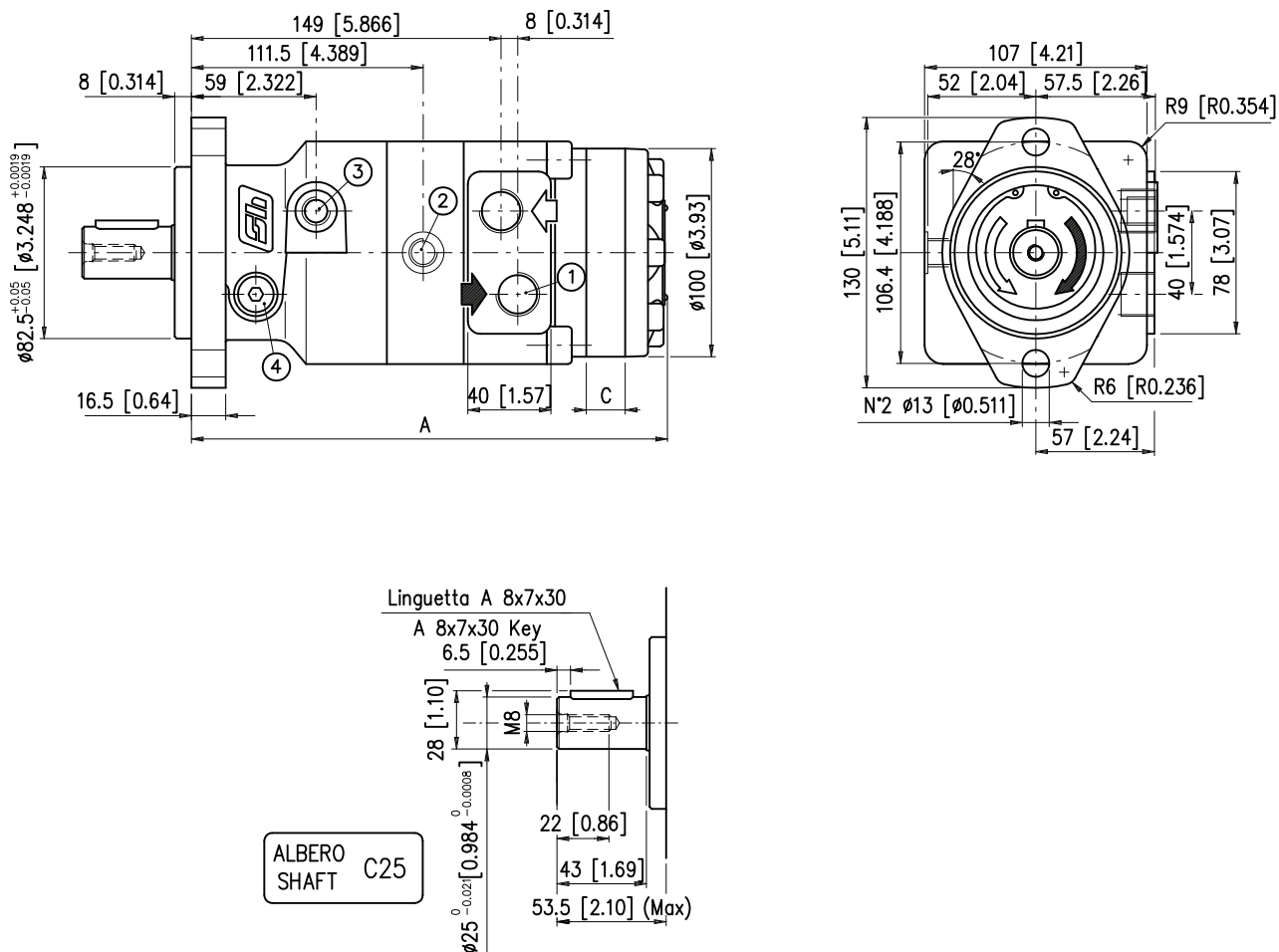

- 1) N° 2 fori di alimentazione 1/2 G (BSPP) profondità filetto 18mm
 No. 2 1/2 G (BSPP) main ports thread depth 0.70 in
- 2) Drenaggio motore 1/4 G (BSPP) profondità filetto 13mm
 1/4 G (BSPP) drain motor thread depth 0.511 in
- 3) Foro comando apertura freno 1/4 G (BSPP) profondità filetto 13mm
 Brake releasing plug 1/4 G (BSPP) thread depth 0.511 in
- 4) N°2 tappi carico-scarico olio freno 1/4 G (BSPP) profondità filetto 13mm
 N°2 brake filling and drain plugs 1/4 G (BSPP) thread depth 0.511 in

		ARF 50	ARF 80	ARF 100	ARF 130	ARF 160	ARF 200	ARF 250	ARF 315	ARF 400
A	mm [in]	220 [8.66]	225 [8.85]	228.4 [8.99]	232.8 [9.16]	238.8 [9.40]	245.8 [9.67]	254.5 [10.01]	265.8 [10.46]	279.3 [10.99]
C	mm [in]	9 [0.354]	14 [0.551]	17.4 [0.68]	21.8 [0.85]	27.8 [1.09]	34.8 [1.37]	43.5 [1.71]	54.8 [2.15]	68.38 [2.69]
Pesi - Weight	kg [lb]	13.5 [29.7]	13.8 [30.4]	14.1 [31]	14.3 [31.5]	14.6 [32.1]	15.1 [33.2]	15.8 [34.8]	16.3 [35.9]	16.9 [37.2]

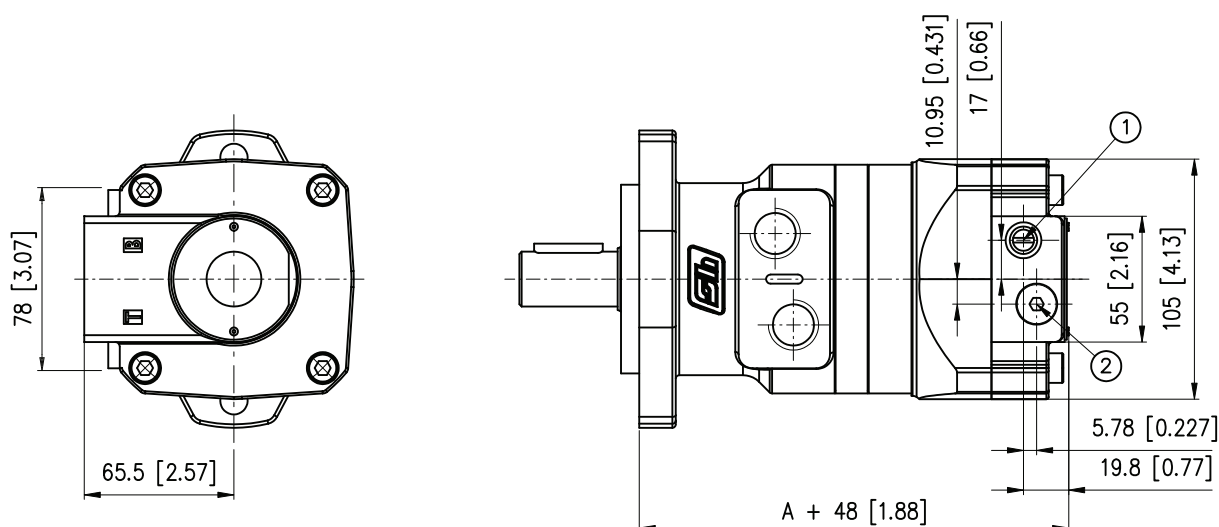

Freno disponibile sui motori: ARS - ARSW
Brake available on following engines: ARS - ARSW

- 1) **Comando apertura freno 1/4 G (BSPP) profondità filetto 13mm**
1/4 G (BSPP) brake releasing port; thread depth 0.511 in
- 2) **Drenaggio Motore 1/4 G (BSPP) profondità filetto 13mm**
1/4 G (BSPP) drain port thread depth 0.511 in

La quota "A" è riferita al dimensionale del motore senza freno FP
"A" Dimension is related to motor length without FP brake

CARATTERISTICHE FRENI BRAKE FEATURES

I freni integrati dei motori ARF e FP sono a dischi multipli negativi ad apertura idraulica.

Questi freni agiscono sotto la spinta di una serie di molle su coppie di dischi alternati fissi e mobili; lo sbloccaggio avviene per effetto della pressione idraulica nel pistone. Questo tipo di funzionamento, chiamato "Negativo", è idoneo per impieghi come freno di stazionamento o di sicurezza, quindi in presenza di una frenatura statica e non per frenatura dinamica, funzione che deve essere svolta dal sistema idraulico. Nel caso di utilizzo dinamico del freno, da noi sconsigliato, è necessario contattare l'ufficio tecnico SAMHYDRAULIK S.p.A. Le alte velocità di rotazione, specie per i freni FP, oppure prolungati funzionamenti con asse verticale, possono generare elevati aumenti di temperatura e quindi mal funzionamento del freno; consigliamo di contattare l'ufficio tecnico SAMHYDRAULIK S.p.A.

The ARF and FP motors have a multi-plate disc brake built in, which is hydraulically released.

This mechanical type brake has springs that push together the plates, which are mounted side by side, so that a static braking action is obtained. Whenever an hydraulic pressure acts on the piston, the brake is released. The so called "negative brake" is suitable for duties like parking or safety brakes and/or whenever a static braking action is required. A dynamic braking action must be obtained using the hydraulic circuit. If a motor is to be used for dynamic braking (which is unadvisable) please contact SAMHYDRAULIK Engineering Service first. High rotation speed and/or vertical position use of the motor might cause discs to overheat, particularly in FP brakes, and consequential malfunctioning. In this case, please contact SAMHYDRAULIK Engineering Service.

Caratteristiche del freno:	ARF (*)	Brake features:
Pressione di apertura minima	22 bar [319 psi]	Mimimum releare pressure
Pressione di freno libero	27 bar [391.5 psi]	Complete brake release press.
Pressione massima	200 bar [2900 psi]	Max. pressure
Coppia massima statica	350 Nm [257.9 lbf·ft]	Max static torque

(*) :

La camera del freno nella versione ARF é separata dal drenaggio del motore e richiede 80 cm³ di olio idraulico.

The ARF motor has a separate brake chamber which must be filled with 80 cm³ of hydraulic oil.

Caratteristiche del freno:	FP	Brake features:
Pressione di apertura minima	22 bar [319 psi]	Mimimum releare pressure
Pressione di freno libero	25 bar [362.5 psi]	Complete brake release press.
Pressione massima	160 bar [2320 psi]	Max. pressure
Coppia massima statica	370 Nm [272.6 lbf·ft]	Max static torque
Velocità massima motore	350 rpm	Max motor speed

Accorgimenti per l'installazione

• Il motore idraulico con freno posteriore FP richiede obbligatoriamente il collegamento del drenaggio motore, posto sul corpo freno, in serbatoio a scarico libero. Mediante tale accorgimento si smaltisce il calore generato dall'attrito del freno.

• Nel caso di motori del tipo ARF si consiglia l'utilizzo per l'impianto frenante di oli resistenti al calore e all'invecchiamento, con viscosità ISO VG 32 e indice di viscosità pari o superiore a 95.

• Nel caso di funzionamento in circuito aperto è consigliato l'utilizzo di una valvola di ritardo chiusura freno, per evitare il funzionamento dinamico dello stesso.

Nella pagina successiva sono riportati alcuni schemi di applicazioni più usuali.

Installation layout

• The FP hydraulic motors must always have the drain port (on casing) directly connected with tank. This improves oil cooling, which is important to avoid brake overheating.

• It is advisable to use heat and wear resistant hydraulic oils in ARF type motors: viscosity grade ISO VG 32; viscosity index ³ 95

• If open circuit layout is needed, it is advisable to use a flow control valve on brake piston ports, in order to avoid dynamic braking.

Common application layouts on following page.

CIRCUITO APERTO, UN MOTORE FRENO, ROTAZIONE IN ENTRAMBE LE DIREZIONI ED AZIONAMENTO FRENO AUTOMATICO.

Questa è la tipica configurazione di un sistema di rotazione (gru, escavatori, piattaforme mobili, falconi, etc.). Quando la pompa invia olio al motore la pressione aziona la valvola di commutazione che, attivando la linea del freno, ne consente il rilascio. La valvola doppia overcentre rallenta la massa in rotazione fino quasi all'arresto quando entra in azione il freno statico.

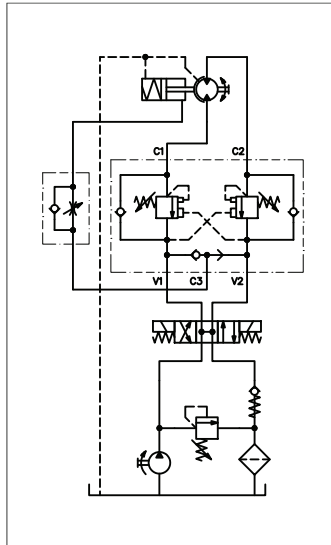

OPEN LOOP SYSTEM , ONE BRAKE-MOTOR, BI-DIRECTIONAL TURNING AND AUTOMATIC BRAKE OPERATION.

This configuration is typically that of a slew drive (cranes, excavators, aerial platforms, derricks, etc.). When the pump delivers oil to the motor the consequent generation of pressure will operate the shuttle valve and activate the brake line, thus disengaging the brake itself. When the oil delivery is shut off to stop the machine, a double overcentre valve will slow down the rotating mass to an almost complete stop when the static brake will engage.

CIRCUITO APERTO, DUE MOTORI FRENO, ROTAZIONE IN ENTRAMBE LE DIREZIONI ED AZIONAMENTO AUTOMATICO DEL FRENO.

Questo è uno schema abbastanza comune di un impianto di traslazione per macchine mobili (piattaforme aeree, etc.). Il fluido in pressione sblocca il freno e fa partire i due motori; una apposita valvola collega i due motori o in serie o in parallelo in modo da avere più velocità o più coppia. La doppia valvola overcentre rallenta con sicurezza la macchina e la porta fino quasi all'arresto quando i due freni statici entrano in funzione.

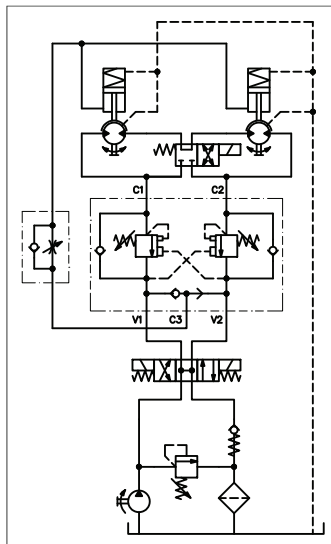

OPEN LOOP SYSTEM , TWO BRAKEMOTORS, BI-DIRECTIONAL TURNING AND AUTOMATIC BRAKES OPERATION.

This is a typical layout of the travelling system of a mobile machine (aerial platforms, etc.). Fluid under pressure disengages the brakes and starts the two motors; a commutation device will connect the two motors either in series or parallel mode in order to have either speed or torque as main performance. The double overcentre valve will steadily slow down the machine and bring it to an almost complete stop when the brakes will engage.

CIRCUITO CHIUSO, UN MOTORE FRENO, ROTAZIONE IN ENTRAMBE LE DIREZIONI, FRENATURA AUTOMATICA, POMPA A PORTATA VARIABILE.

Questo è un tipico impianto di traslazione per spazzatrici ad una ruota motrice. La pompa impiegata consente di azionare il motore a velocità variabile. Il freno viene bloccato dall'invio di olio dalla valvola commutatrice attraverso l'elettrovalvola che consente anche il deflusso del fluido in pressione dalla camera del freno quando il motore si arresta ed il freno stesso entra in azione.

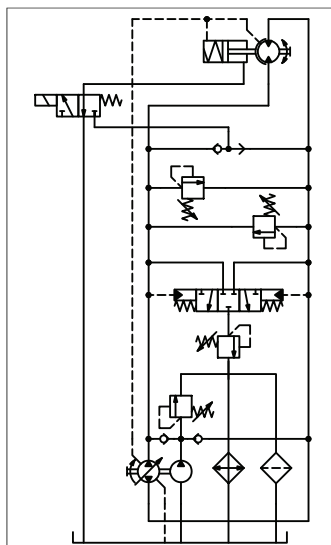

CLOSED LOOP SYSTEM, ONE BRAKEMOTOR, BI-DIRECTIONAL TURNING, AUTOMATIC BRAKE OPERATION AND VARIABLE PUMP.

A very typical system for sweepers. The pump delivers a variable flow of oil to the motor hence the machine can travel at variable speed. The brake is disengaged by the deliver of flow from the shuttle valve via the electrovalve (top, right) that will also release the fluid under pressure from inside the brake piston chamber when the motor stops and the brake engages.

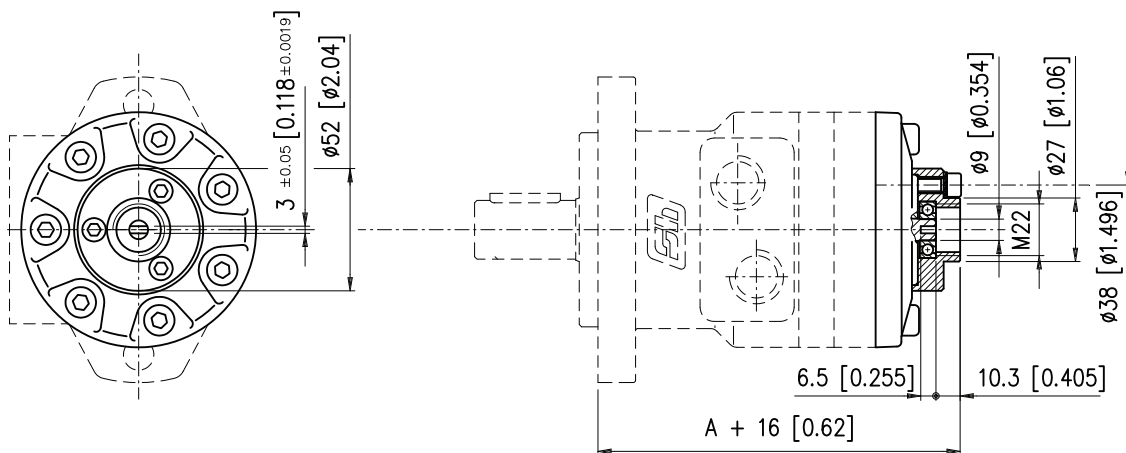

Contagiri disponibile sui motori: **ARS**
Tacho-meter available on motors: **ARF**

ATTENZIONE: L'albero contagiri ha velocità pari a 6 volte quella dell'albero primario del motore a senso di rotazione opposto.
WARNING: The tacho shaft revolution speed is 6 times more than the motor one and opposite direction of rotation.

N.B.: Non sono accettati carichi assiali o radiali sull'albero contagiri. Coppia massima trasmissibile 1 Nm.
NOTE: Axial or radial load on tacho shaft must be avoided. Max torque on tacho shaft 1 Nm [0.73 lbf-ft].

La quota "A" è riferita al dimensionale del motore senza contagiri.
"A" dimension is related to motor length without tacho.

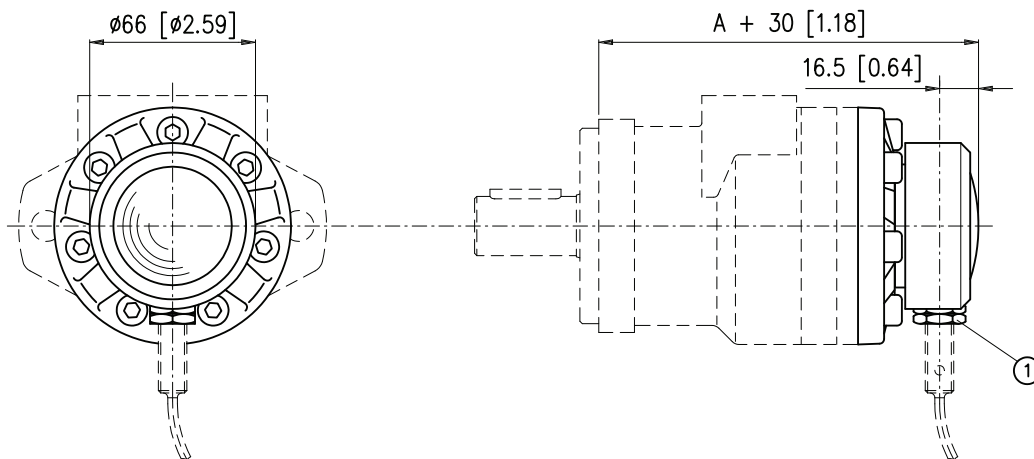

Contagiri elettronico disponibile sui motori: **ARS, ARF**

Electronic tacho-metre available on motors: **ARS, ARF**

Numero d'impulsi per giro = 90

Number of pulses per revolution = 90

La quota "A" è riferita al dimensionale del motore senza contagiri elettronico

"A" dimension is related to motor length without electronic tacho

1) Attacco sensore M8x1

1) Sensor thread M8x1

ATTENZIONE:

WARNING

– Il motore viene fornito senza il sensore elettronico: se necessario, richiederlo in fase di ordinazione.
– Pressione massima ammessa in carcassa: 20 bar.

– The electronic sensor is not supplied: if required, please state it clearly on order form.
– Max case pressure admissible on the shaft seal with closed drain port: 20 bar [290 psi].

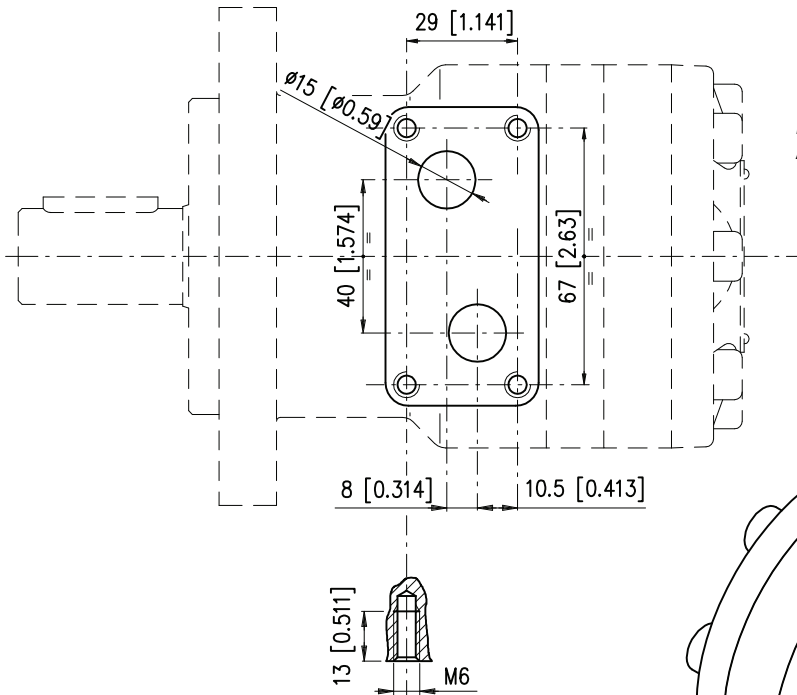

Predisposizione disponibile per i motori: ARS
Available for the following motors:

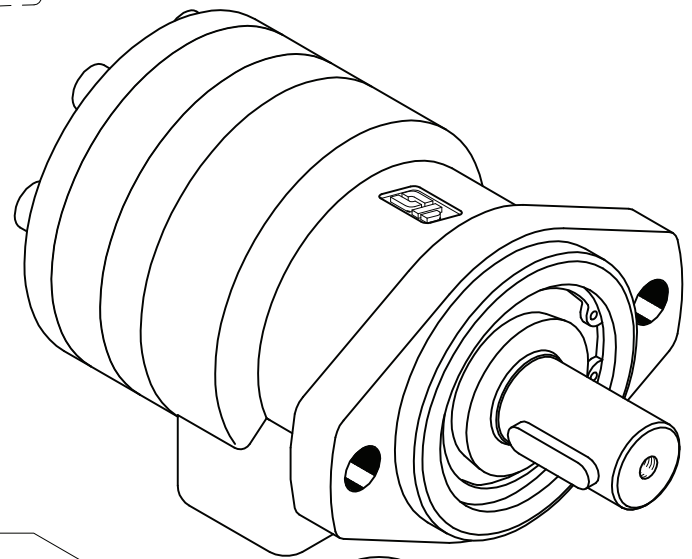

- 2 Guarnizioni O-Ring 2-117 (cod. 410.0160.0000)
- 2 O-Ring gaskets 2-117 (cod. 410.0160.0000)

- 1 Collettore BFL1 (cod. 321.0010.0000)
- 1 BFL1 manifold (cod. 321.0010.0000)

- 4 Viti T.C.E.I. M6x35 (cod. 490.0206.0350)
- 4 T.C.E.I. screws M6x35 (cod. 490.0206.0350)

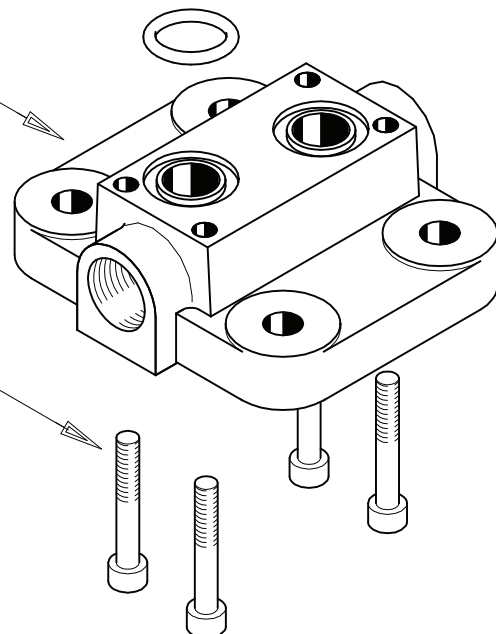

N.B. L'ordine del "KIT" BFL 1, o dei singoli particolari, deve essere eseguito a parte (cod. Kit 109.0100.9000)
NOTE: The BFL 1 "KIT" or the single components must be ordered separately (Kit Code: 109.0100.9000)

AR 50

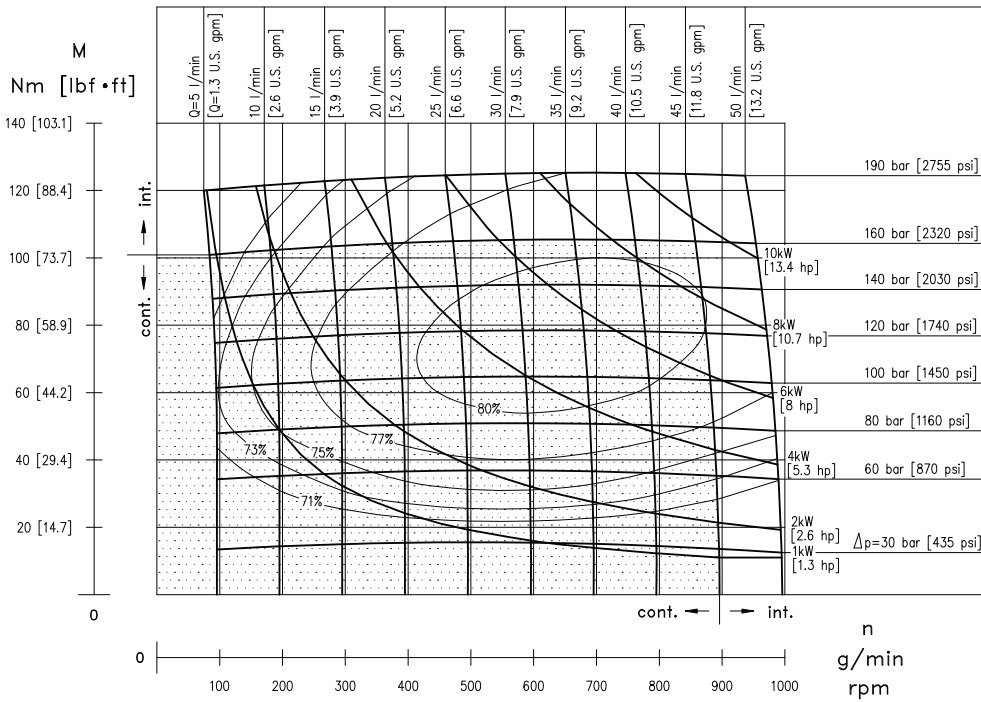

Pressioni e portate superiori a quelle ammesse in regime continuo non devono essere applicate contemporaneamente. Exceeding continuous pressure values or exceeding flow values indicated, must not occur simultaneously.

AR 80

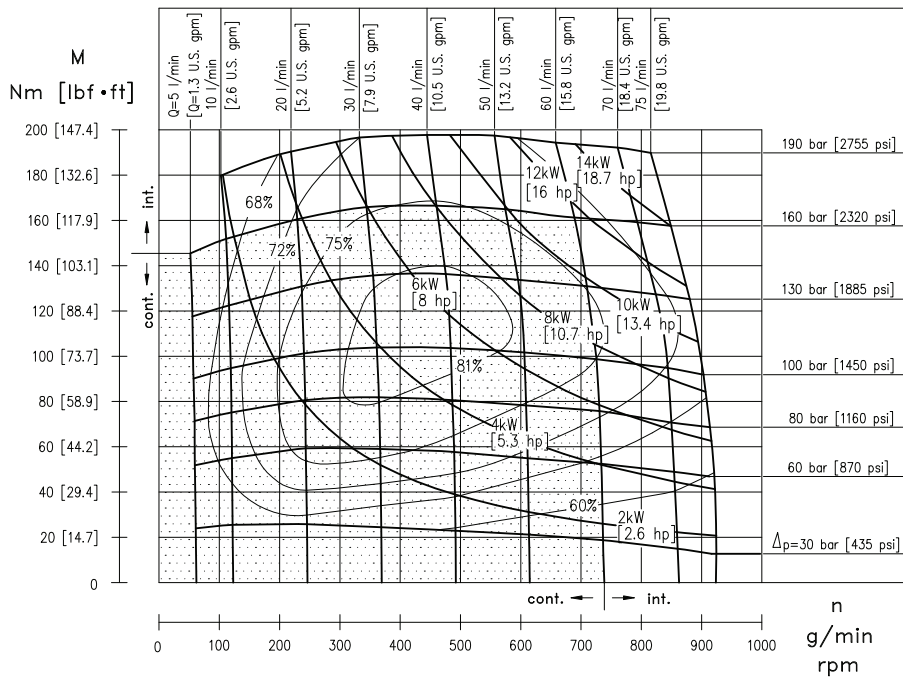

Pressioni e portate superiori a quelle ammesse in regime continuo non devono essere applicate contemporaneamente. Exceeding continuous pressure values or exceeding flow values indicated, must not occur simultaneously.

AR 100

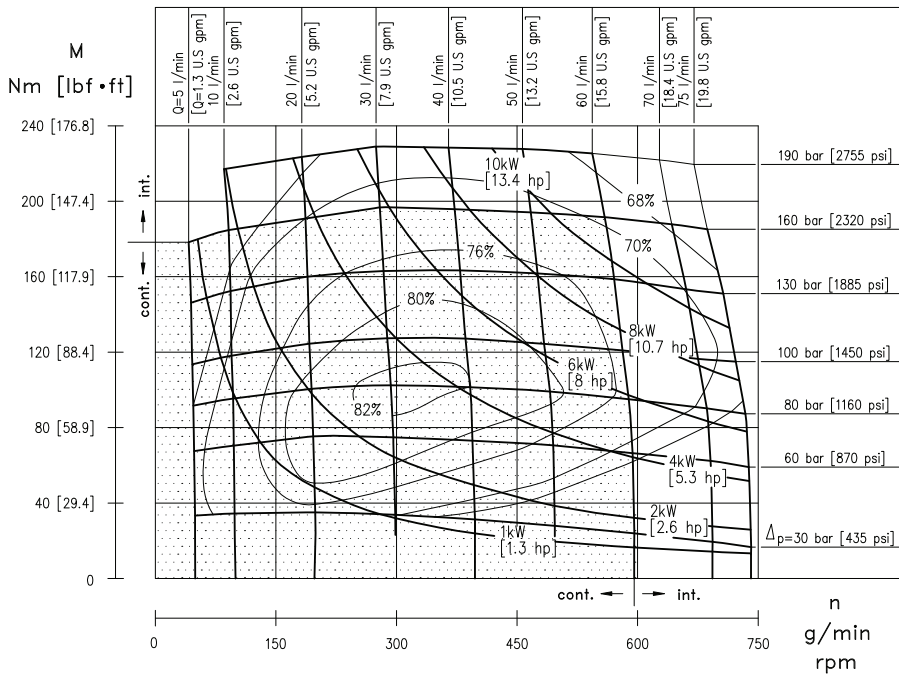

Pressioni e portate superiori a quelle ammesse in regime continuo non devono essere applicate contemporaneamente. Exceeding continuous pressure values or exceeding flow values indicated, must not occur simultaneously.

AR 130

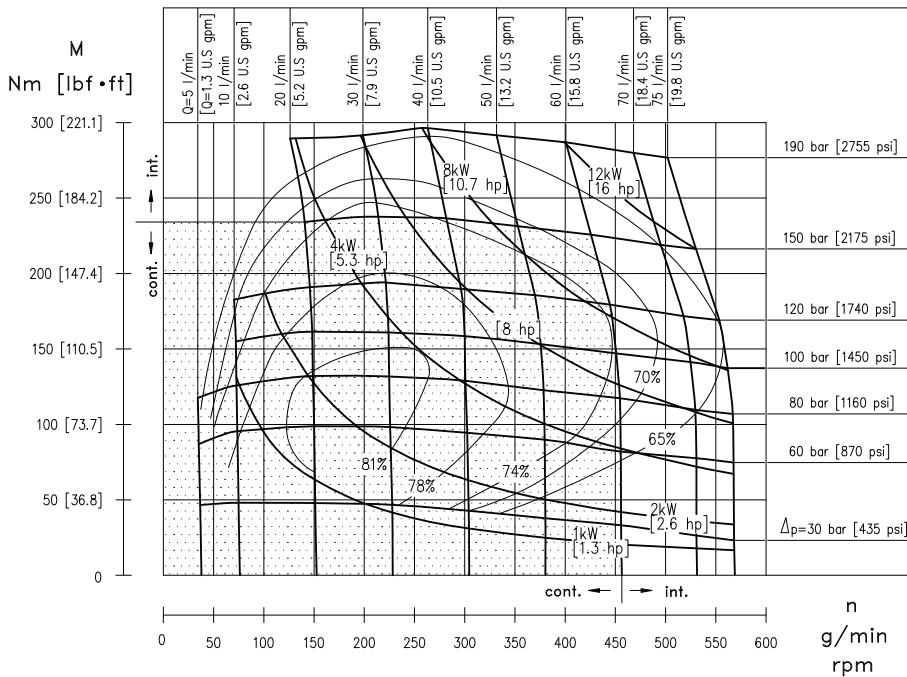

Pressioni e portate superiori a quelle ammesse in regime continuo non devono essere applicate contemporaneamente. Exceeding continuous pressure values or exceeding flow values indicated, must not occur simultaneously.

AR 160

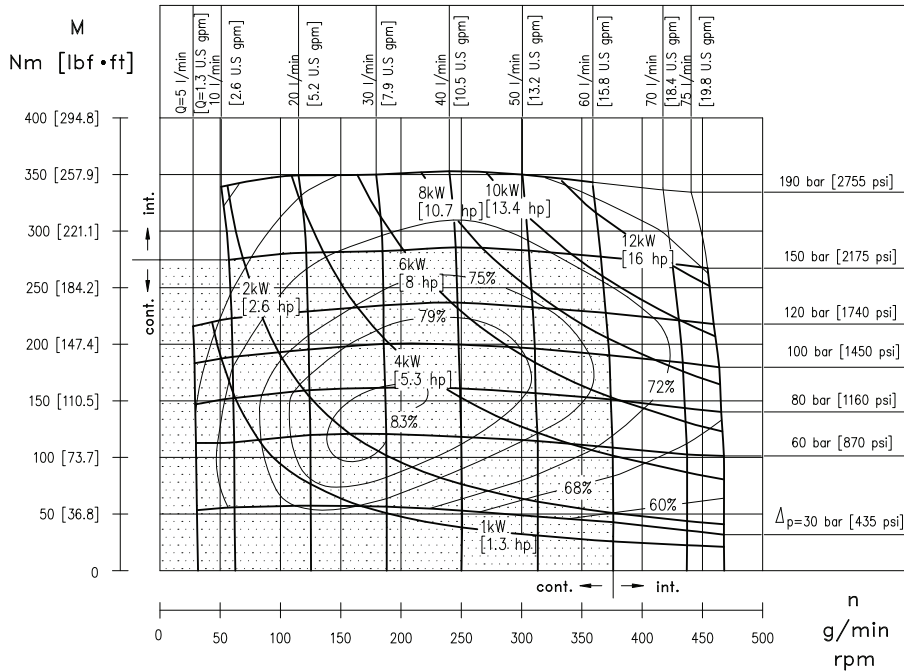

Pressioni e portate superiori a quelle ammesse in regime continuo non devono essere applicate contemporaneamente. Exceeding continuous pressure values or exceeding flow values indicated, must not occur simultaneously.

AR 200

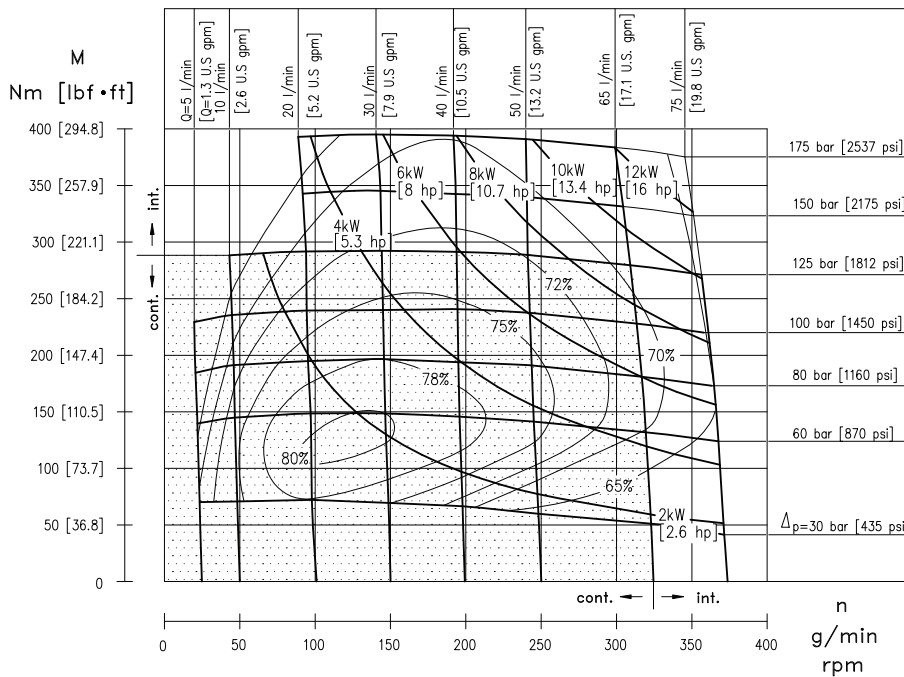

Pressioni e portate superiori a quelle ammesse in regime continuo non devono essere applicate contemporaneamente. Exceeding continuous pressure values or exceeding flow values indicated, must not occur simultaneously.

AR 250

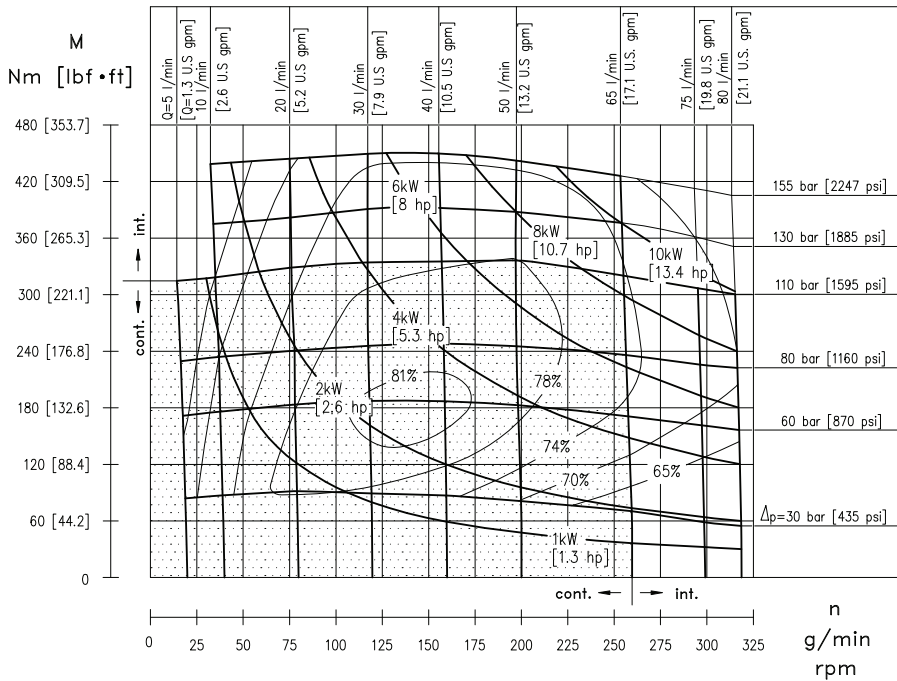

Pressioni e portate superiori a quelle ammesse in regime continuo non devono essere applicate contemporaneamente. Exceeding continuous pressure values or exceeding flow values indicated, must not occur simultaneously.

AR 315

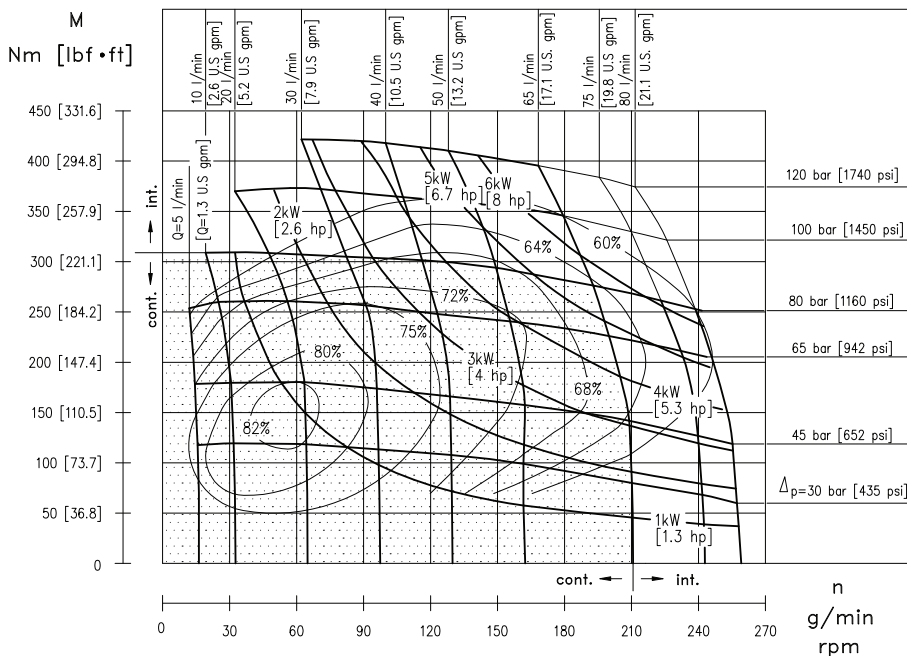

Pressioni e portate superiori a quelle ammesse in regime continuo non devono essere applicate contemporaneamente. Exceeding continuous pressure values or exceeding flow values indicated, must not occur simultaneously.

AR 400

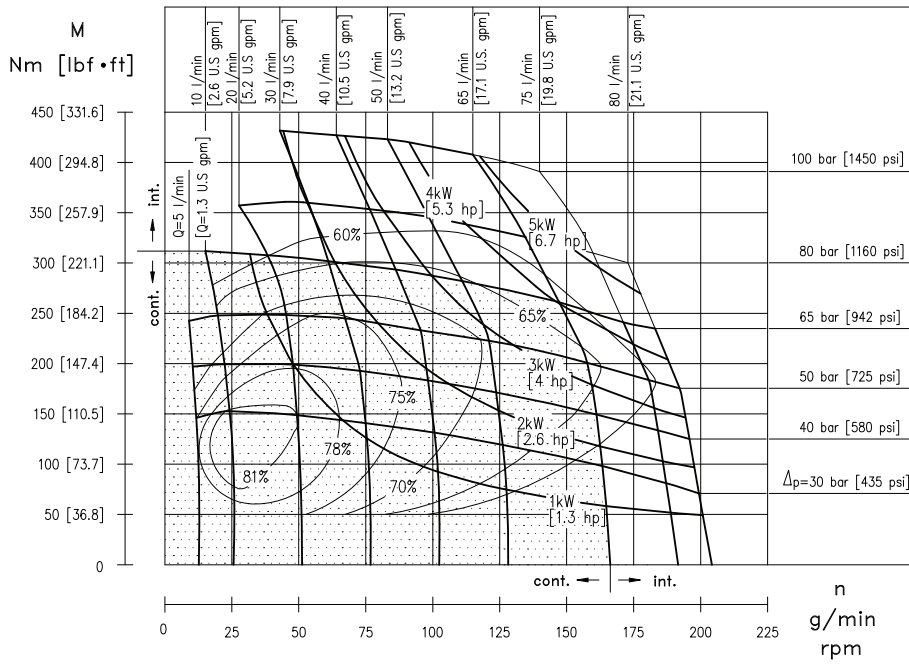

Pressioni e portate superiori a quelle ammesse in regime continuo non devono essere applicate contemporaneamente.

Exceeding continuous pressure values or exceeding flow values indicated, must not occur simultaneously.

CARICHI AMMESSI SULL'ALBERO SHAFT LOAD CAPACITY

ARS

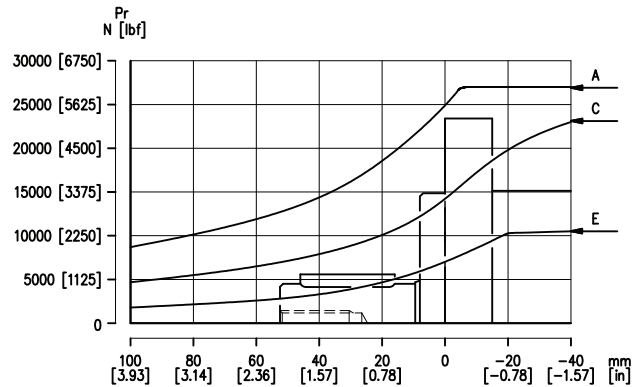
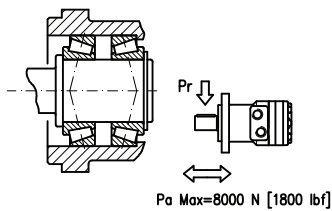

ARSW

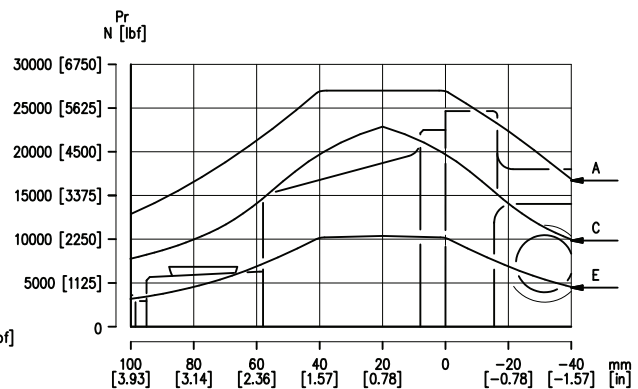
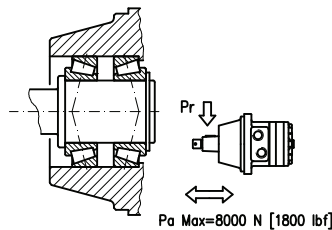

ARF

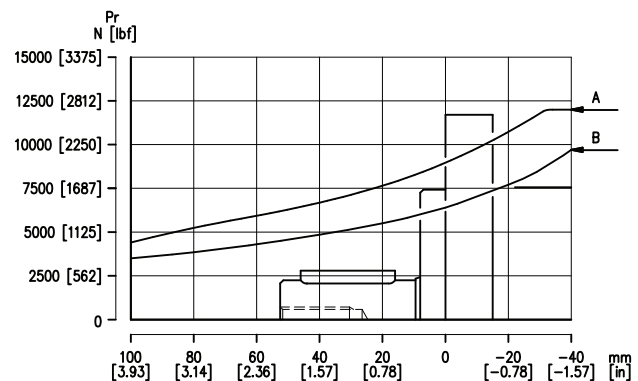
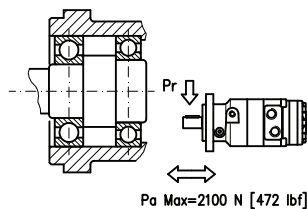

I diagrammi dei carichi sono validi per una vita dei cuscinetti di 1.600 ore a 200 min⁻¹, in rif. alla norma ISO 281 (3.3.) lubrificati con olio a base minerale contenente additivi antiusura.

La curva "A" evidenzia il carico statico massimo sopportabile dai cuscinetti.

La curva "B" fornisce il carico radiale limite senza nessuna forza assiale concomitante.

La curva "C" fornisce il carico radiale limite in concomitanza con una forza assiale pari a 2000 N.

La curva "D" fornisce il carico radiale limite in concomitanza con una forza assiale pari a 6000 N.

La curva "E" fornisce il carico radiale limite in concomitanza con una forza assiale pari a 8000 N.

The load diagrams are valid for an average bearings life of 1.600 hrs at 200 r.p.m. with mineral base lubricating oil containing anti-wear additives (ref. ISO 281 (3.3) standard).

The "A" curve gives the maximum static load affordable by the bearings.

The "B" curve gives the radial load top limit without axial loading.

The "C" curve gives the radial load top limit with an axial load of 2000 N [450 lbf].

The "D" curve gives the radial load top limit with an axial load of 6000 N [1350 lbf].

The "E" curve gives the radial load top limit with an axial load of 8000 N [1800 lbf].

Informazioni sul prodotto

Dati i continui sviluppi, le modifiche e le migliorie al prodotto, la S.A.M. Hydraulik Spa non sarà responsabile per eventuali informazioni che possano indurre in errore, od erronee, riportate da cataloghi, istruzioni, disegni, dati tecnici e altri dati forniti dalla S.A.M. Hydraulik Spa. Non sarà possibile basare alcun procedimento legale su tale materiale.

Modifiche del prodotto. La S.A.M. Hydraulik Spa si riserva il diritto di variare i suoi prodotti, anche quelli già ordinati, senza notifica.

Notice

Due to the continuous product developments, modifications and improvements S.A.M. Hydraulik Spa will not be held responsible for any erroneous information or data that may lead to errors, indicated in catalogues, instructions, drawings, technical data and other data supplied by S.A.M. Hydraulik Spa. Therefore, legal actions cannot be based on such material. **Product development.** S.A.M. Hydraulik Spa reserves the right to make changes to its products, even for those already ordered, without notice.
